



Pendant Alarm Plan - User Guide

Please read and keep these instructions for future use

 0800 180 85 40

 support@telecare24.co.uk

Important information



The user's telephone **MUST BE** connected to the Novo telephone socket - a double adapter on the incoming line must not be used.



If the user has a DECT telephone the base station **MUST BE** at least 2 metres away from the Novo. Failure to provide this separation may result in reduced range of personal pendants or other radio devices.



REN 1

All telephone equipment has a Ringer Equivalence Number (REN) which is used to calculate the number of items that can be connected to a single telephone line. A REN of 4 is the maximum allowed on a standard UK telephone line. The Novo has a REN of 1. If the REN total of all equipment connected to a telephone line exceeds 4, the equipment may not operate correctly. With different types of equipment there is no guarantee of correct operation even if the REN is less than 4. Typically 1 or 2 standard telephones (REN1) can be used with the Novo.



Avoid using strong detergents or polish when cleaning the Novo base unit or Smile pendant. Wipe clean with a damp cloth and polish with a dry duster. Do not leave Novo unit in direct sunlight or near a heat source.

What's in the box?

In the box you'll find; a Novo base unit, a smile pendant, wearing kit, power lead, a telephone lead and an adaptor cable.



Novo Base unit



Smile pendant



Wearing kit



Adaptor cable



Telecom lead



Power supply

The Smile pendant



As the Smile pendant is a life saving device; remember to wear it at all times. Please test your system via pressing your pendant every 4-6 weeks to ensure that all equipment is working correctly.

Wearing your Smile pendant

You can wear your Smile pendant either on the wrist or around the neck depending on your preference during purchasing.

If you've chosen to wear it on the wrist, the smile should be worn on your non-dominant hand (the opposite hand to the one you write with).

The pendant is waterproof but it should not be submerged for long periods.

How to call for help using the Smile pendant

1. Press the pendant until it flashes red.
2. When the alarm is activated, you can speak to our control centre using the microphone and loudspeaker on the base unit.

(Please note, the pendant does not have a microphone, we'll speak to you via the loudspeaker on your base unit.)



The base unit



The Novo will usually be table mounted within 3 metres of a mains supply and the master telephone socket. If extension cables are used care should be taken to ensure that no one trips over the leads.



What if I'm not near the base unit?

If we cannot reach you via the base unit, we will call your landline once to ensure everything is okay. If there is no response on the landline, we will call keyholders or if the situation requires emergency services.

Connections

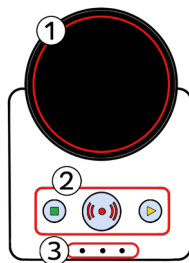

Top view

- 1) Speakers
- 2) Buttons
- 3) Front LEDs

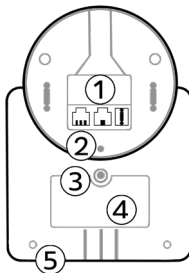

Bottom view

- 1) - Connectors
 - Home phone cable (left)
 - BT wall socket lead (mid)
 - Mains supply (right)
- 2) Bottom cover screw
- 3) Power button
- 4) Product label area
- 5) Microphone

Setup / placing a test call

Getting started



1. Unplug the telephone from the wall socket and plug into Novo telephone adaptor cable.



2. Connect the Novo telephone cable into the telephone socket on the wall (where the telephone was originally plugged in).



3. Connect the power lead between the base unit supply socket and the mains electricity.



4. Turn on the base unit by pressing the grey on/off button for roughly 5 seconds underneath the unit.



5. Place a test call to the control centre to verify installation and programming by pressing your pendant.

Placing a test call

(1). Press the red button on the base unit or press the pendant.

(2). The base unit will make a series of tones as the unit dials through to the monitoring centre. It can take up to 40 seconds to connect.

(3). Moments later, you'll be connected to our emergency response team. Simply tell our team that you are making a test call to check that your alarm is working correctly.

(4). Your alarm is set up and ready should you need it.

Existing telecom equipment

If broadband is present an ADSL filter should be provided by your chosen provider.

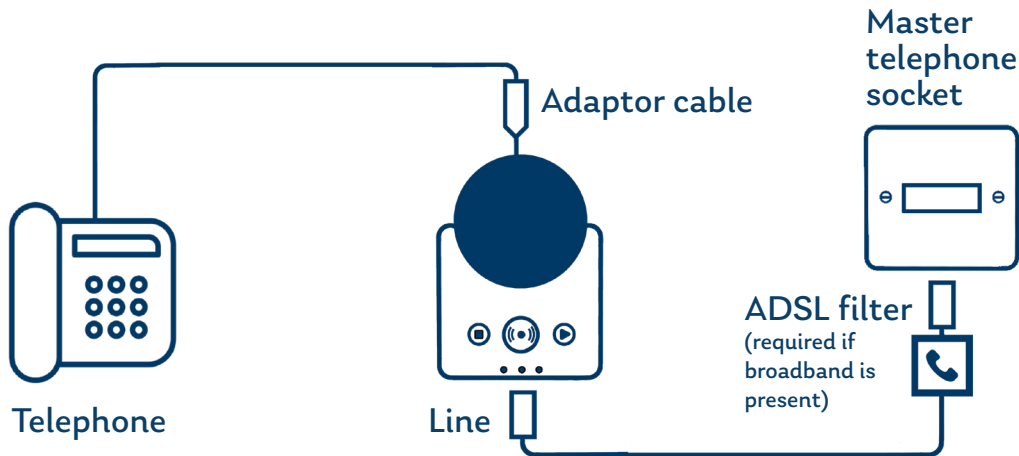

i If you have any connection issues or noise on the base unit audio, then a poor quality filter may be the cause.

Switching the base unit on / off

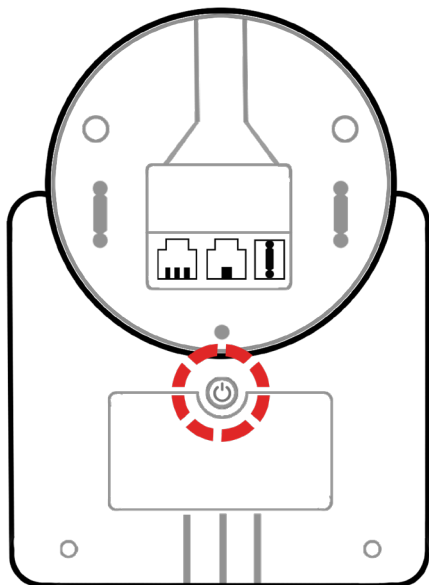

Switching on

1. Switch the mains power supply on.
2. Power on the base unit by pressing the grey power button on the back of the unit for roughly 3 seconds.
3. You will see the lights on the unit run through a cycle and then your alarm will be ready to use.

(Only the red 'alarm' button should be illuminated.)

Switching off

The base unit uses very little power, we advise keeping it switched on at all times.

If it is necessary to switch the unit off, follow these steps:

1. At the back of the unit you will find a grey power button.
2. Press the button for 3 second and release.

(You will hear a beep and the base unit will power down).