

## WALL MOUNTED SHOWER & CHANGING TABLES

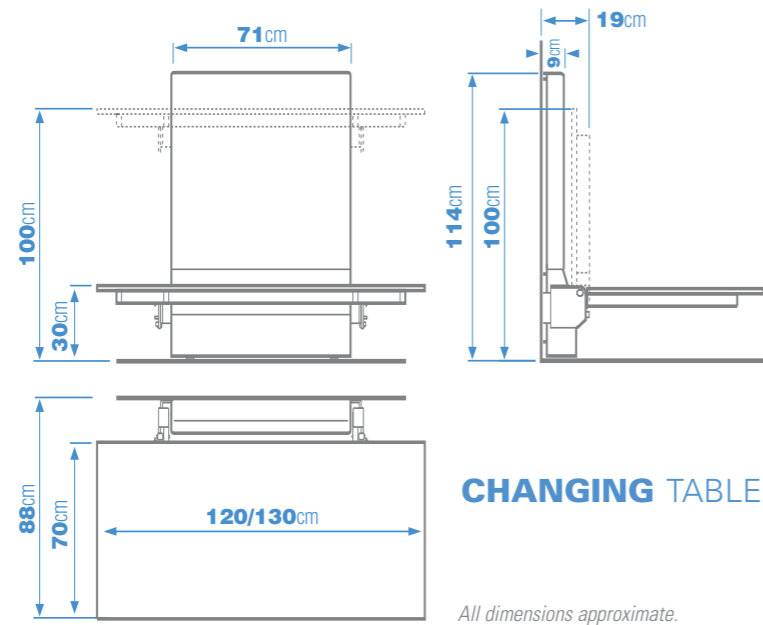
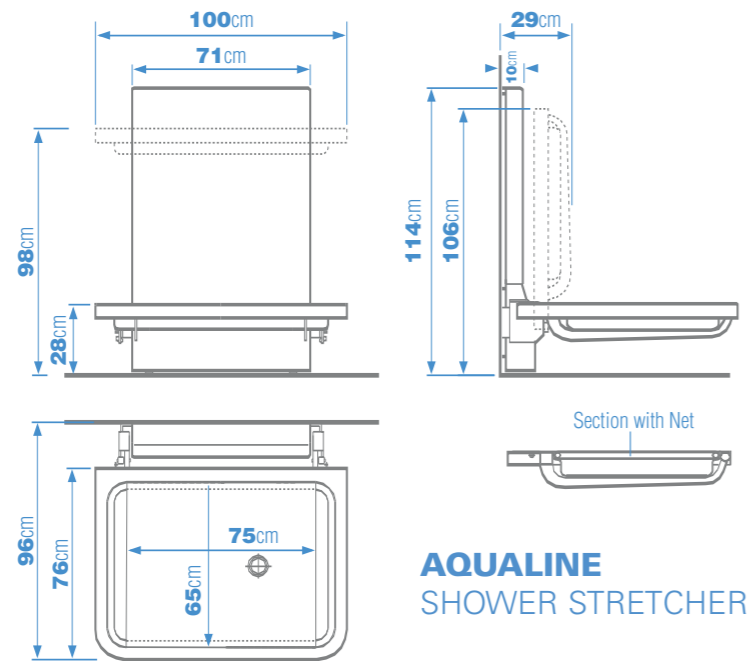

### *Kingkraft Customer Care*

The following services are offered to make the process of choosing your Kingkraft product as straight forward as possible. Kingkraft Care continues following delivery to ensure the products continue to provide the maximum benefit.

- Product demonstration and assessments
- Room layout design and drawing
- Technical support both prior to order and following delivery
- Product commissioning
- 12 month product warranty (extended warranties available)
- On-going product servicing and preventative maintenance schemes

For full details of these services please contact our customer service department or refer to our product information folder.



**Kingkraft**  
KINGKRAFT

Kingkraft Limited, 26D Orgreave Crescent, Dore House Industrial Estate, Sheffield S13 9NQ  
Telephone: 0114 269 0697 Fax: 0114 269 5145 Email: info@kingkraft.co.uk Web: www.kingkraft.co.uk

Due to the process of continuous development we reserve the right to alter specification without notice.

**Kingkraft**  
KINGKRAFT

## WALL MOUNTED SHOWER TABLE

*Assisted showering (wet areas)*

Kingkraft are pleased to offer the Aqua-line range of wall mounted shower tables. Wall mounted shower tables are designed for rooms which will always require a means of showering and /or changing. The tables fold up when not in use to save space and the unique, slim design of the Aqualine range ensures that the product is as un-obtrusive as possible.

Drainage of water around the user and table is often a concern to carers so the water collection tray located underneath allows for water to drain away through a centrally mounted drainage point via a flexible hose.

The height of the table can be lowered to 30cm and raised, electrically, to 100cm and so offers flexibility for transferring the user whilst enabling a good working position for the carer.

The soft waterproof material provides a comfortable area for the user with the additional feature of an adjustable backrest as an option.



### standard features

- Folds up for convenience
- Collection tray under table for controlled drainage of water
- Slim, unobtrusive design
- 120kg SWL
- Comfortable, washable nylon mesh surface
- 30 to 100cm range of lift
- Electrically operated with handset
- Smooth operation for client reassurance
- 100 and 180cm length models available

### additional options

- Side rail for increased security
- Side padding
- Adjustable backrest

## WALL MOUNTED CHANGING TABLE

*Assisted changing (dry areas)*

For dry environments the changing tables are designed to enable changing on a variable height table allowing for improved working posture for the carer.

The table can be 120, 140, 160 or 180cm in length to suit user requirements.

With a hygienic laminate surface, the table provides a comfortable, practical base upon which a user can be dressed/changed.



### standard features

- Cushioned Surface
- Available in four lengths: 120, 140, 160, 180cm
- 30–100cm range of lift
- Slim, compact design