

Fitting & User Instructions for: Recliner & Riser Recliner Chair Raisers CR-C3 & CR-C3S

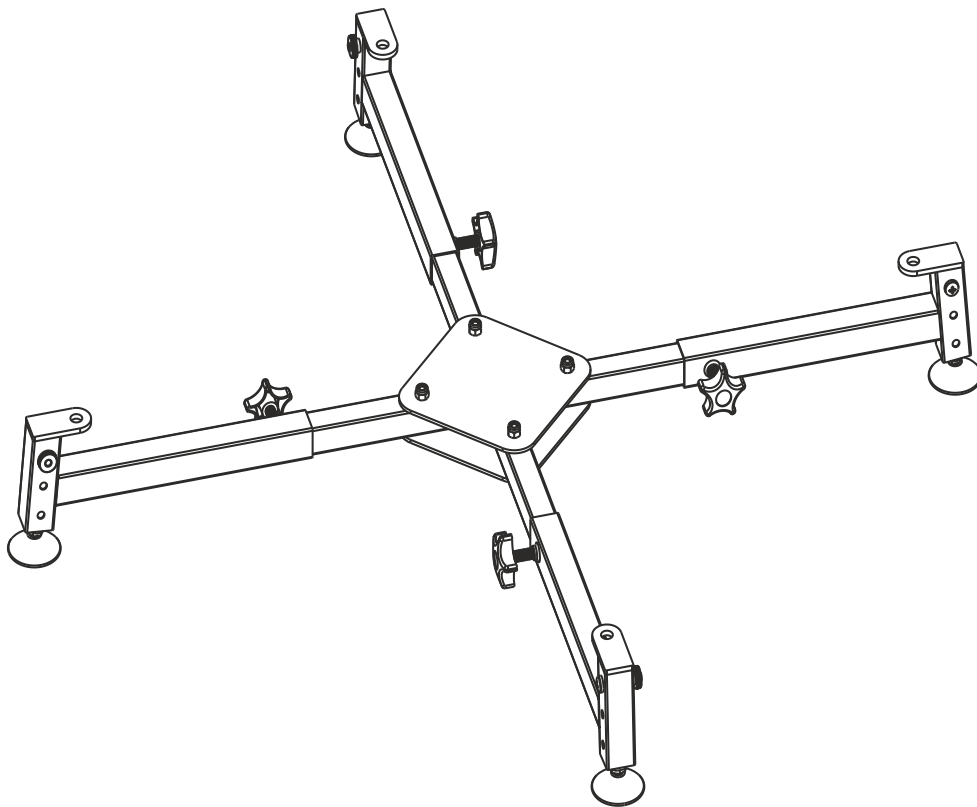

**This Chair Raiser should be fitted by a competent person.
Please read these instructions thoroughly before attempting to fit the raiser.**

Important!!

This Chair Raiser will not fit every Recliner and Riser Recliner Chair. It is very important to establish if this raiser will fit your chair, failure to do so could result in damage to your chair.

If in any doubt contact:

Morris & Alexander on 01328-855669 or e-mail info@morrisandalexander.com

IDENTIFY IF YOUR CHAIR CAN BE RAISED

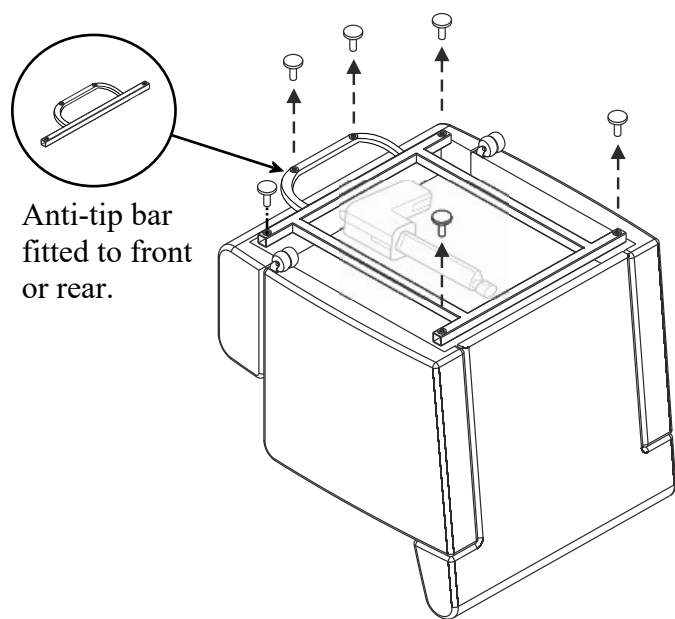
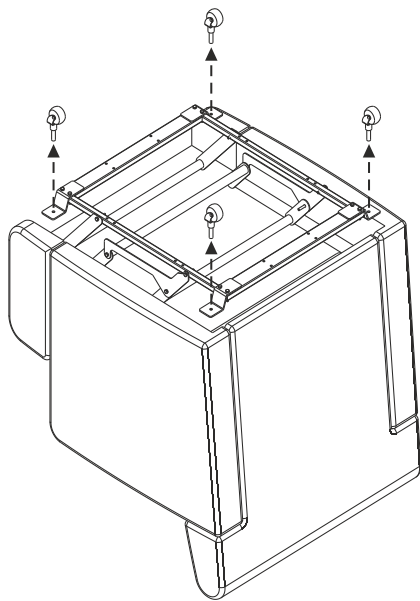

Anti-tip bar fitted to front or rear.

CAN BE RAISED

Recliners or Riser Recliners that:-

- Has no anti-tip bar.
- Have only 4 feet or 4 castors.
- Do not have feet/castors that are visible under the arms of the chair when elevated (Riser Recliners only).

CANNOT BE RAISED

Recliners or Riser Recliners that:-

- Have an anti-tip bar.
- Have more than 4 feet or 4 castors combined.
- Have feet/castors not in contact with the floor in its elevated condition - (Riser Recliners only).

IDENTIFICATION OF PARTS

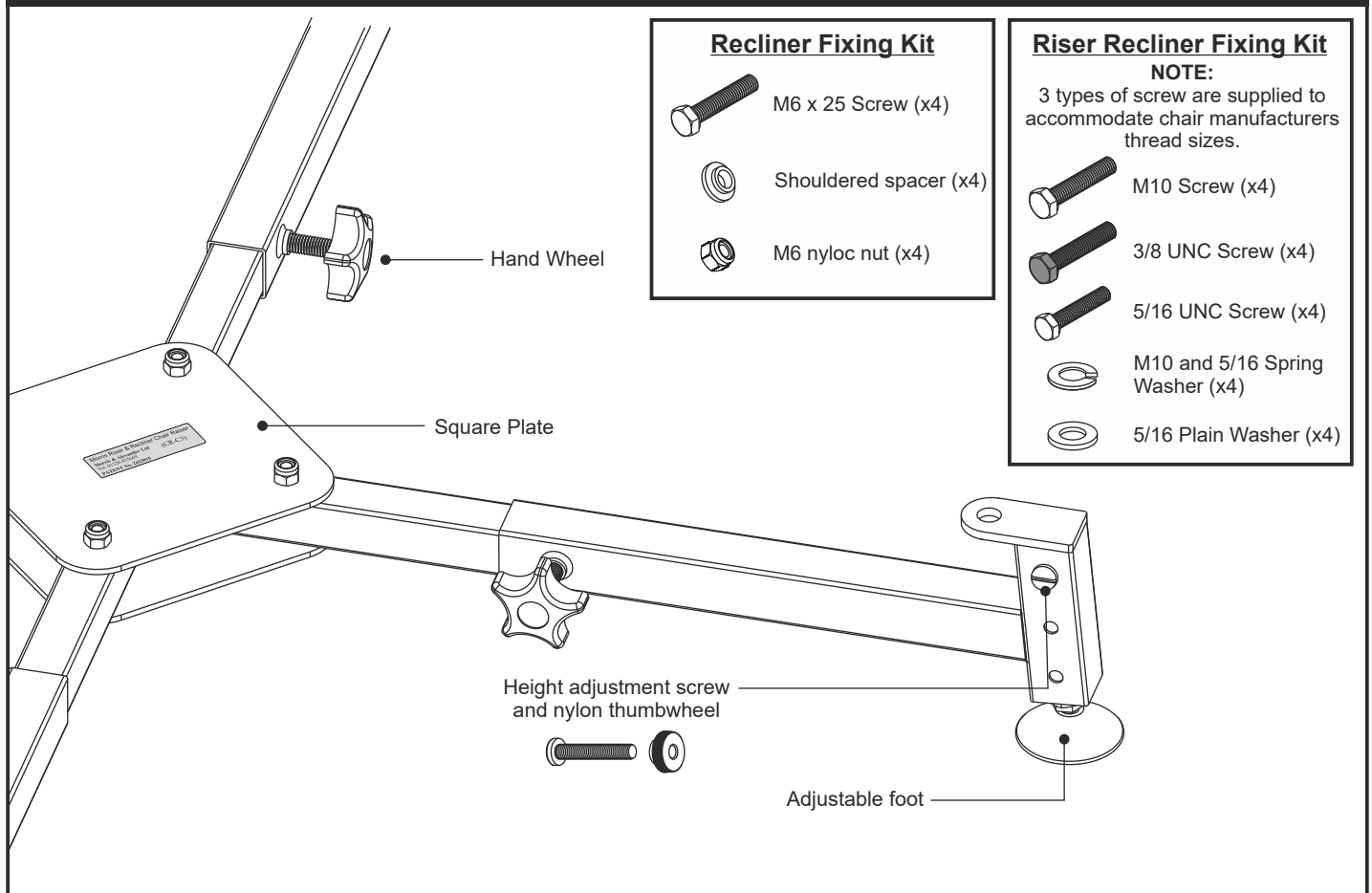

These instructions apply to the raising of recliner & riser-recliner chairs with castors or feet.

Max Weight Loading - 508 Kg (80 Stone).

Please read these instructions carefully before installation.

User precautions:

- This product is only to be used for the purpose for which it is intended (for increasing the height of a Recliner or Riser Recliner Chair).
- Ensure that the raised furniture is stable before use.
- This raiser is for indoor use only.
- Check tightness of hand wheels and fixings periodically.
- Clean with damp cloth. Use a non-abrasive detergent and dry thoroughly.

Recliner Chairs - Manual or electrically operated.

- 1** Position the chair upside down. This is easily achieved by slowly tipping the chair forward until it comes to rest with its underside facing upwards.
- Remove castors or feet as shown below (fig 1a). Insert M6x25mm screw with shouldered spacer (fig 1b). Offer up the raiser to the chair and enter the M6 screw into the castor fixing holes of the chair. You will have to loosen the hand wheels of the raiser to achieve this (fig 1c).

If the raiser is too big for the chair then arrange the raiser legs as shown (fig 1d) to reduce the raiser's size.

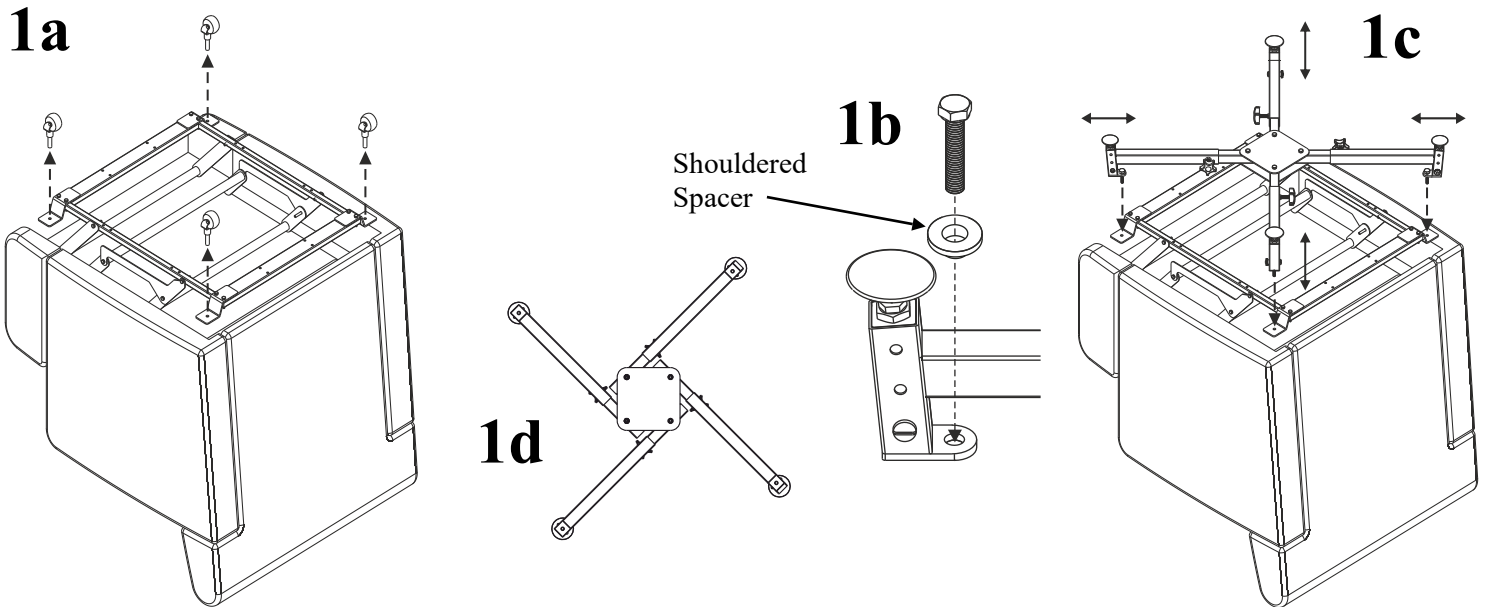

- 2** Position the square plate centrally to the legs and then tighten all the hand wheels. Secure the raiser using the supplied M6 nyloc nuts in all four positions (fig 2a). Adjust legs to required height and secure using height adjustment screw and thumbwheel (fig 2b).

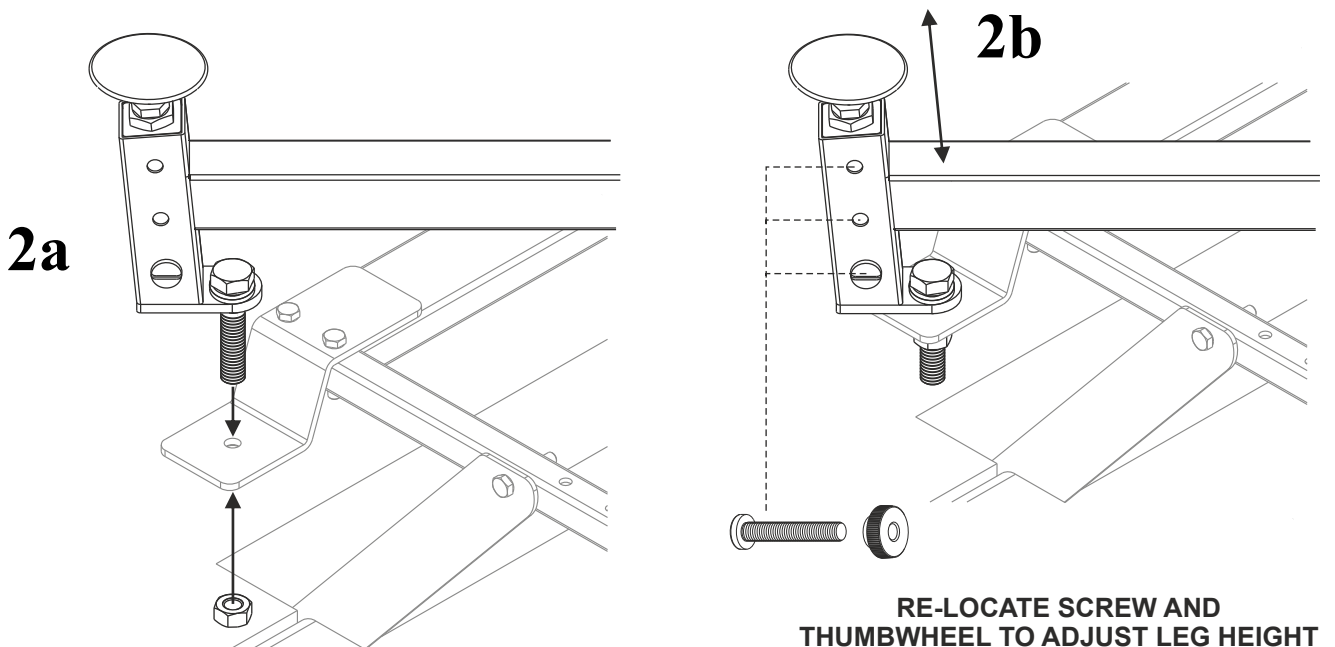

Carefully place the chair upright by reversing the procedure in '1'. The raiser is now fitted and ready for

Notes:

1. Check the raised chair for stability before use.
2. In order to achieve the lowest possible raise, remove the screw-in-feet altogether. It is advisable in this case to place castor cups (not supplied) under the raisers legs to protect the carpet from indentation.
3. Images of furniture in these instructions are figurative and simplified for clarity. The design of your recliner chair may differ from these images. If in any doubt about the fixing of this raiser to your recliner chair, please contact Morris & Alexander Ltd. 01328 855669

Riser Recliner Chairs - Single or dual motors.

- 1** Position the chair upside down. This is easily achieved by slowly tipping the chair forward until it comes to rest with its underside facing upwards.
- Remove feet or levellers as shown below (fig 1a). If the levellers or feet are attached with nuts then retain these nuts for use in stage 2. Offer up the raiser to the chair and align the fixing holes in the raiser with the fixing holes of the chair. You will have to loosen the hand wheels of the raiser to achieve this (fig 1b).

If the raiser is too big for the chair then arrange the raiser legs as shown (fig 1c) to reduce the raiser's size.

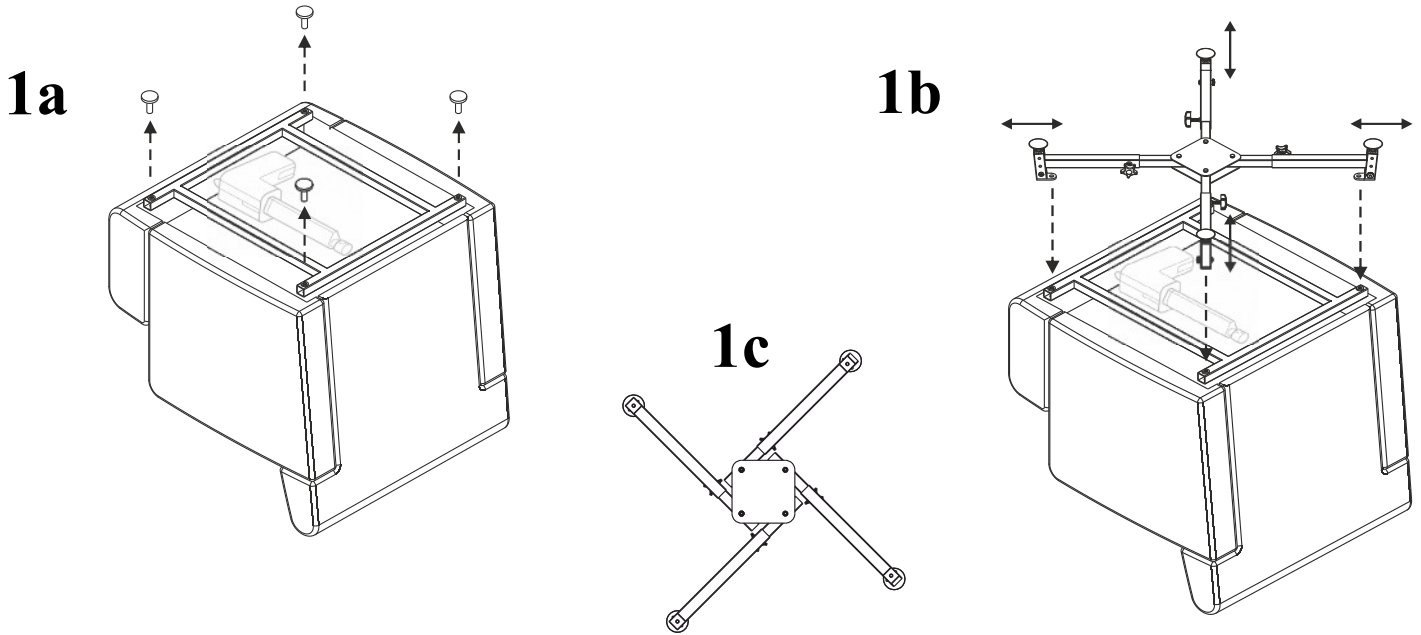

- 2** For chairs with threaded fixing points, secure the raiser legs to the chair using the appropriate screws in all four positions (fig 2a). For chairs with through-hole fixing points use the previously removed nuts to secure the screws. Position the square plate centrally to the legs and then tighten all the hand wheels. Adjust leg to desired height and secure using height adjustment screw and thumbwheel (fig 2b).

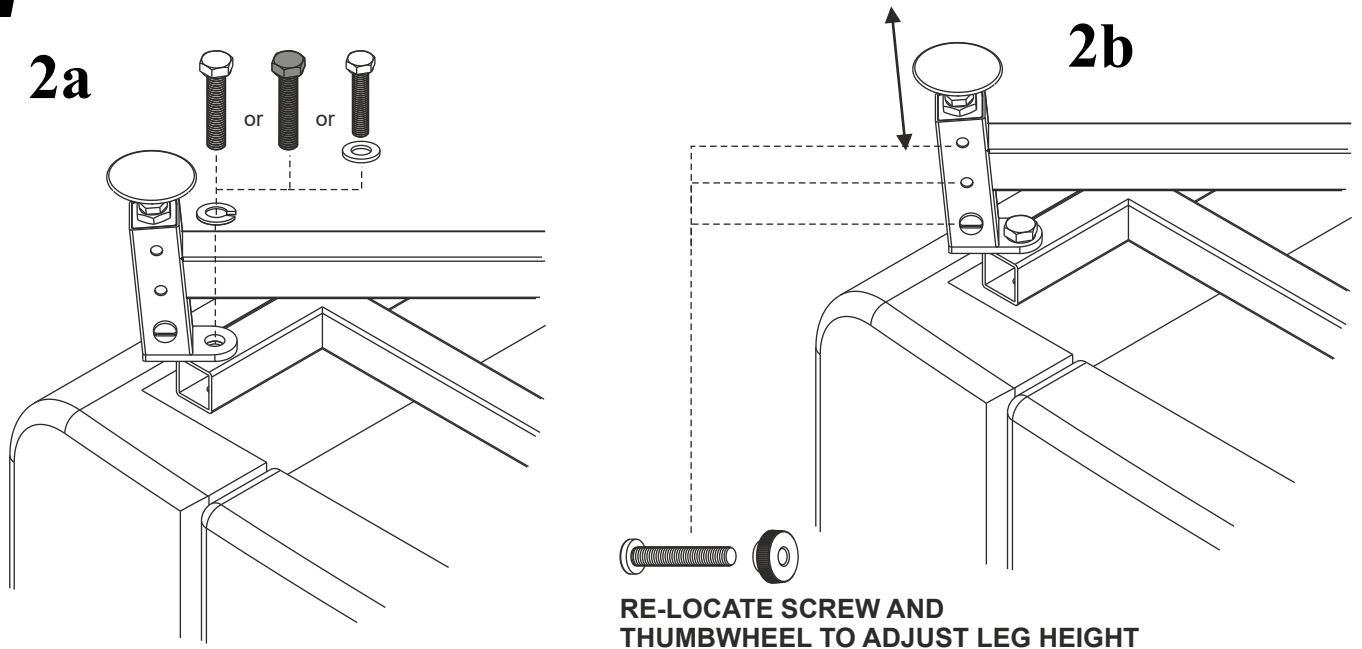

Carefully place chair upright by reversing the procedure in '1'. The raiser is now fitted and ready for use.

Notes:

1. Check the raised chair for stability before use.
2. In order to achieve the lowest possible raise, remove the screw-in-feet altogether. It is advisable in this case to place castor cups (not supplied) under the raiser to protect the carpet from indentation.
3. Images of furniture in these instructions are figurative and simplified for clarity. The design of your chair may differ from these images. If in any doubt over the fixing of this raiser to your recliner chair, please contact Morris & Alexander Ltd. 01328 855699